

Absolute Pressure Gauges Stainless Steel Series, with Diaphragm Element Models 532.51 to 532.54, Class 0.6 ... 2.5

WIKA Data Sheet PM 05.02

Applications

- Measurement of absolute pressure excluding the effect of barometric pressure variation
- Suitable for corrosive environments, gaseous or liquid media
- Monitoring of vacuum pumps
- Control of vacuum packing machines
- Monitoring condensation pressures and used in the determination of vapour pressures of liquids

Special Features

- High overpressure safety
- All welded construction of pressure and reference chamber and therefore a higher long-term tightness
- Manipulations of the system impossible
DT- GM 86 08 176
- Gauges compatible with alarm contacts and transmitter
- Scale ranges from 0 ... 25 mbar absolute pressure

Description

Nominal size

100 and 160 mm

Accuracy class

Model 532.51 160 mm: 0.6
Model 532.52: 1.0
Model 532.53: 1.6
Model 532.54: 2.5

Accuracy in consideration of ambient pressure variation between 955 and 1065 mbar

Scale ranges

0 ... 25 mbar to 0 ... 25 bar absolute pressure or equivalent other units of absolute pressure

Working pressure

Steady: full scale value
Fluctuating: 0.9 x full scale value



Absolute Pressure Gauge Model 532.51

Overpressure safety

10 x scale range 25 bar maximum, minimum 1 bar absolute (atmospheric pressure) with all scale ranges

Operating temperature

Ambient: -20 ... +60 °C
Medium: +100 °C maximum

Temperature effect

When temperature of the pressure element deviates from reference temperature (+20 °C):
max. ±0.8 %/10 K of true scale value

Ingress protection

IP 65 per EN 60 529 / IEC 529

Standard features

Pressure connection (exposed to pressure medium)

Material: stainless steel 1.4571

Lower mount (LM), G ½ B (male), 22 mm flats

Pressure element (exposed to pressure medium)

≤ 0.4 bar: stainless steel 1.4571

> 0.4 bar: Duratherm (NiCrCo-alloy)

Pressure chamber (exposed to pressure medium)

Stainless steel 1.4571

Movement

Stainless steel

Dial

White aluminium with black lettering

Pointer

Adjustable black aluminium pointer

Zero adjustment

By means of adjustable pointer. Contact gauges and liquid filled gauges with external zero adjustment

Case

Natural finish stainless steel case, with pressure vent

Window

Laminated safety glass

Bezel ring

Cam ring (bayonet type), natural finish stainless steel

Gauge mounting

Requires mounting by means of rigid tailpipe

Additional pipe or surface mounting bracket is optionally available

Design and operating principle

- The diaphragm (1) separates pressure chamber (3) and pressure datum chamber (2) which represents absolute zero pressure
- Difference of pressure between pressure chamber (3) and pressure datum chamber (2) will deflect the diaphragm (1)
- The diaphragm will rest against a contoured metal bolster if the pressure applied is greater than maximum scale value
- Metal bellows (4) will seal the datum chamber and provide transmission (5) of the pressure applied to the instruments movement and pointer

Optional extras

- Other pressure connection
- Liquid filling (model 533.XX)
- Safety pattern case (model 53X.3X)
- Overpressure safety in excess of 10 x scale range
- Special material Monel (model 56X.XX)
- Medium temperature in excess of 100 °C
- Pressure connection with DIN or ASME flange
- Pressure connection with vacuum-type flange DN 10/32 to DIN 28 403
- 3-hole panel or surface mounting flange (consider possible conflict with pressure chamber)
- Pipe or surface mounting bracket (see data sheet AM 09.07)
- Alarm contacts (see data sheet AE 08.01)
- Transmitter (see data sheet AE 08.02)

Special versions

Model 532.53 with expanded lower scale range

Pressure range 0 ... 1020 mbar absolute, Scale range

(working range) 0 ... 30 mbar expands over 130°,

Accuracy class 1.6

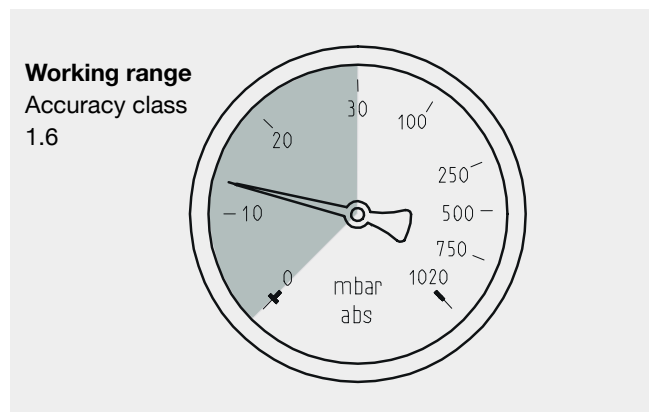
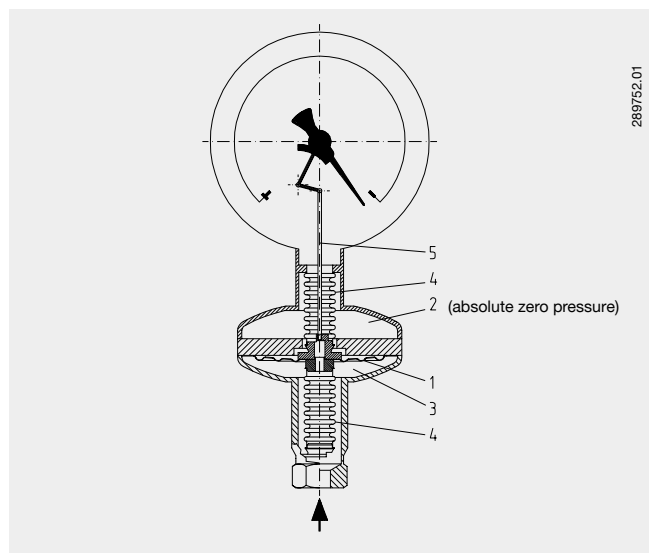
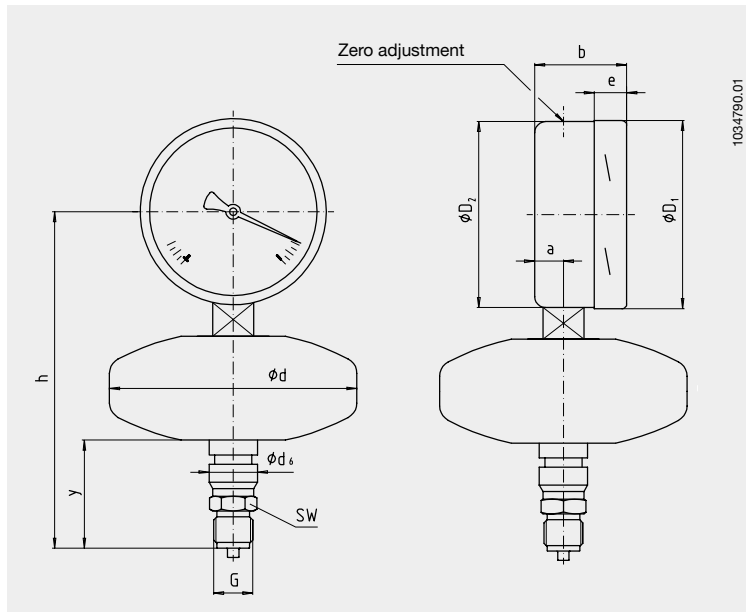

Illustration of the principle



Dimensions in mm

Standard version



NG	Pressure range in bar	Dimensions in mm										Weight in kg	
		a	b	D_1	D_2	d	d_6	e	G	$h \pm 1$	y		SW
100	≤ 0.4	15.5	49.5	101	99	133	26	17.5	G 1/2 B	185	58	22	1.80
100	> 0.4	15.5	49.5	101	99	76	26	17.5	G 1/2 B	177	66	22	1.20
160	≤ 0.4	15.5	49.5	161	159	133	26	17.5	G 1/2 B	215	58	22	2.30
160	> 0.4	15.5	49.5	161	159	76	26	17.5	G 1/2 B	207	66	22	1.60

Standard pressure entry with parallel thread and sealing to EN 837-3 / 7.3

Flanged pressure connection (optional)

Flange to DIN 2501
DN 15 ... 50, PN 6 / 40
feasible

Miniature flange
to DIN 28 403
DN 10 ... 32 feasible

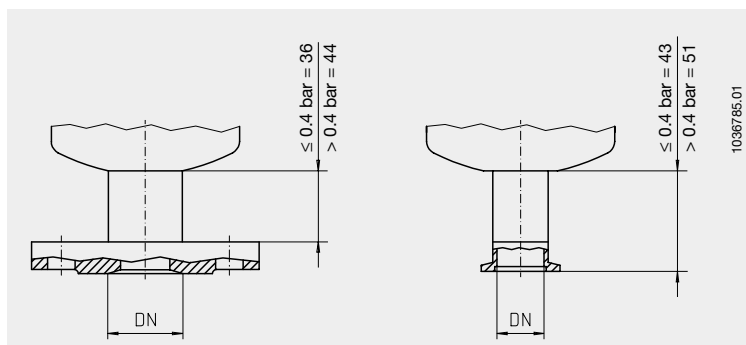

Ordering information

Pressure gauge model / Nominal size / Scale range / Size of connection / Optional extras required

Modifications may take place and materials specified may be replaced by others without prior notice.
Specifications and dimensions given in this leaflet represent the state of engineering at the time of printing.



WIKAI Alexander Wiegand GmbH & Co. KG
Alexander-Wiegand-Straße 30
63911 Klingenberg/Germany
Phone (+49) 93 72/132-0
Fax (+49) 93 72/132-406
E-Mail info@wika.de
www.wika.de